

# MSC Series

## MSC Outline Drawings

### Medium Screw Compressors

#### **MSC 110**

"K" Version

#### **MSC 127**

1210 & 1212 "K" Version

1215 & 1218 "K" Version

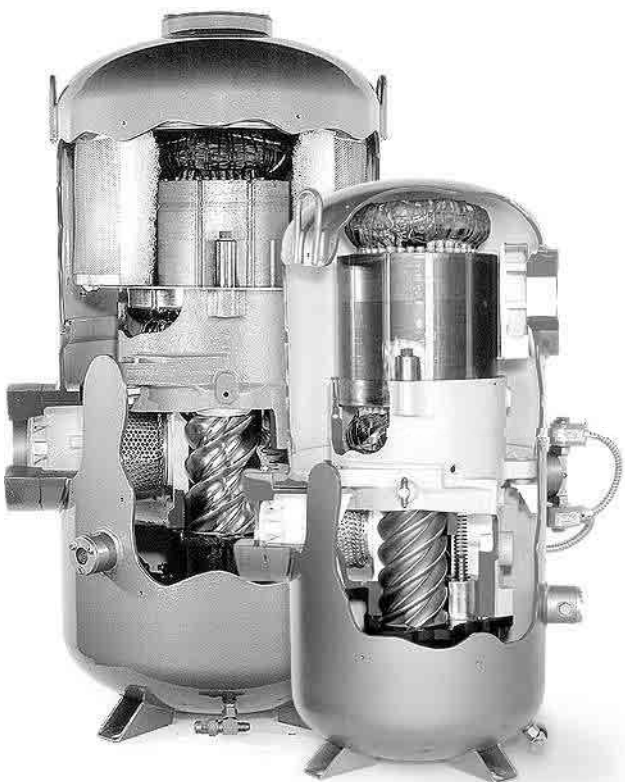

**HARTFORD**<sup>®</sup>

COMPRESSORS

*Pioneers in Screw Compressor Technology*

179 South Street, West Hartford, CT 06110

[www.hartfordcompressors.com](http://www.hartfordcompressors.com)

Back to MSC Outline  
Drawings Menu

DO NOT SCALE  
WORK TO DIMENSIONS SHOWN

REV.	ECN NO.	DATE	ZONE	CHANGES
0	711-0322	12/11/98		RELEASED
1	400-0049	2/8/99	2C 1E	A) ADDED "C6" CONN. & ALL RELATED DIMS B) ADDED TABLE: SUCT LINE WAS 3-5/8 & DISCH LINE WAS 3-1/8 FOR ALL MODELS 1B C) WAS 5.94 2B D) WAS 3.87 SQUARE 2B E) WAS 4.30 DIA. 3B F) WAS 15.20 3B G) WAS 12.10 4C H) WAS 7.00 6C J) WAS 4.63 DIA. 5C K) WAS 4.25 SQUARE 4D L) WAS 18.09 4D M) WAS 14.70 6C N) ROTATED SIGHTGLASS 135° CW AS VIEWED FROM TOP
2	370-0954	FEB 17 2000	3A 3A 3C	A) ADDED DIM. 3A B) ADDED DIM. 3C C) RECONFIGURED UNLOADER ASSY.

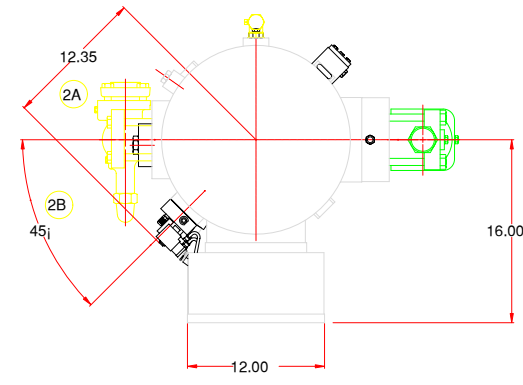

TOP VIEW

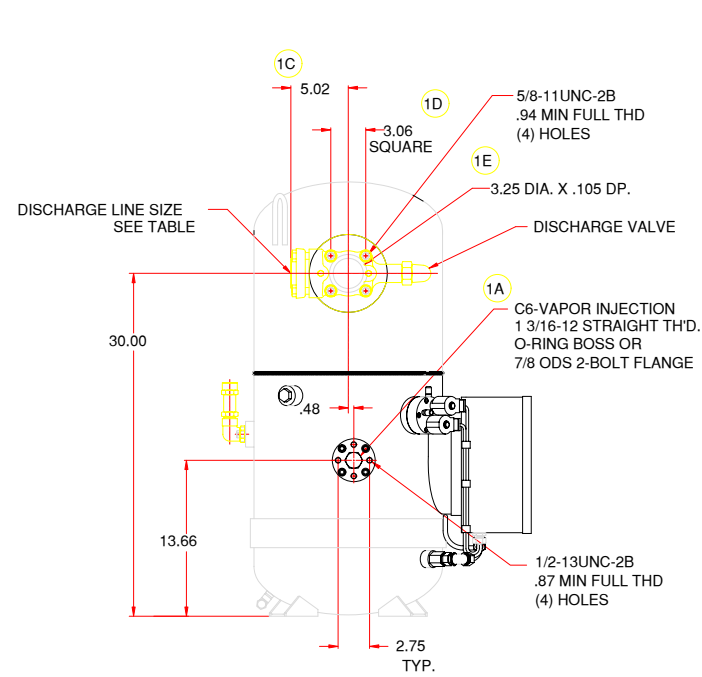

SIDE VIEW

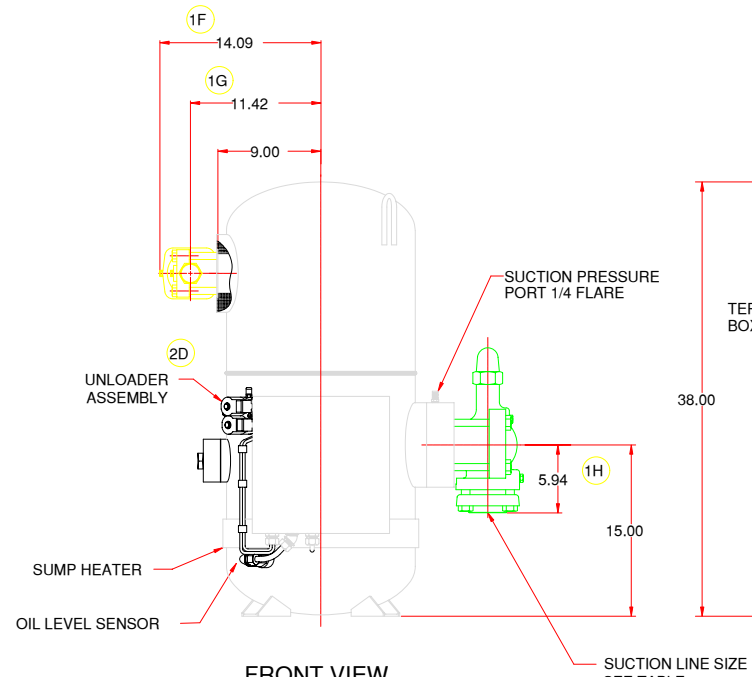

FRONT VIEW

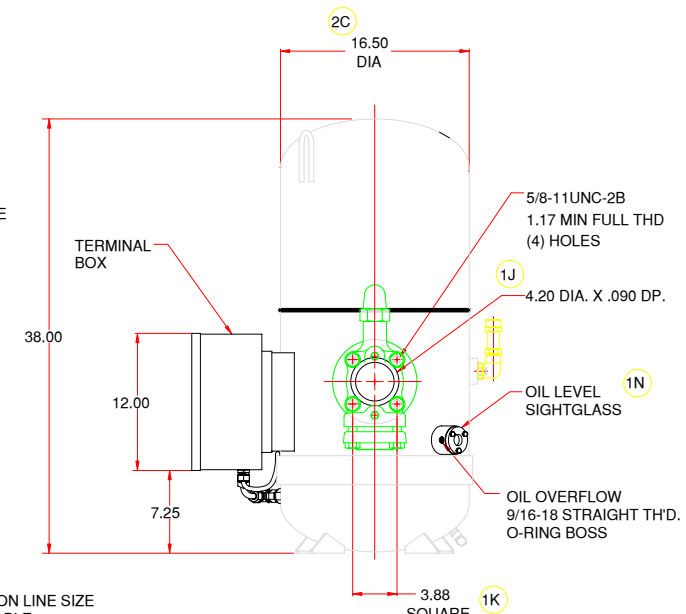

SIDE VIEW

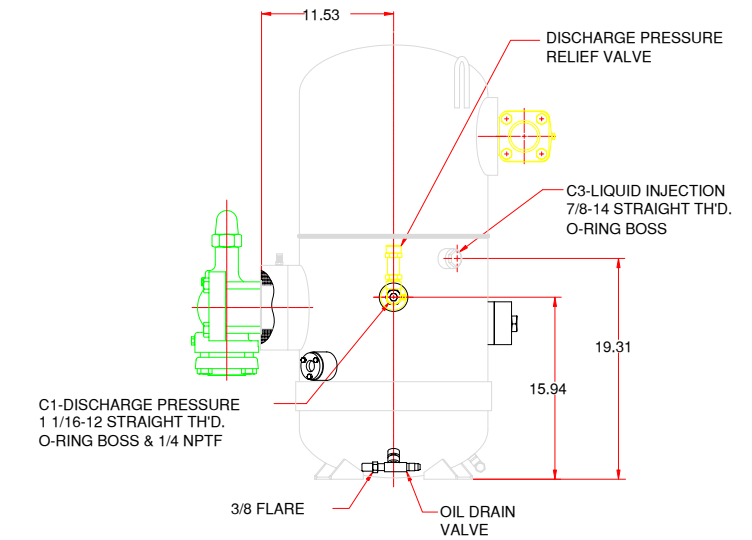

BACK VIEW

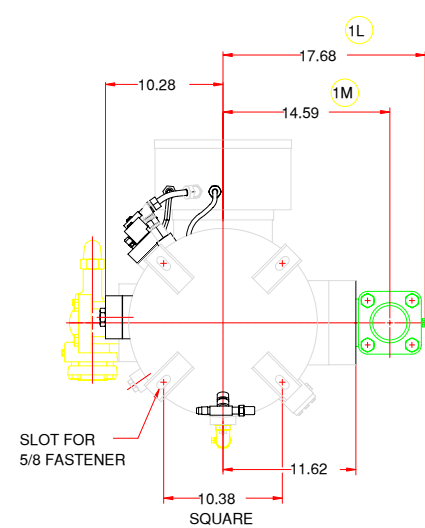

BOTTOM VIEW

1B

SERVICE VALVE LINE SIZES		
MODEL	SUCTION	DISCHARGE
1111	2-5/8	2-1/8
1113	2-5/8	2-5/8
1117	3-1/8	2-5/8

2. TO SHOW COMPRESSOR WITH DISCHARGE AND SUCTION VALVES:  
TURN OFF LAYERS "NO\_DIS\_VAL" & "NO\_SUCT\_VAL".

TO SHOW COMPRESSOR WITHOUT DISCHARGE AND SUCTION VALVES:  
TURN OFF LAYERS "DIS\_VAL" & "SUCT\_VAL".

1. STANDARD COMPRESSOR IS SOLD WITHOUT SERVICE VALVES.

NOTES:

This drawing contains designs and other information which are the property of HARTFORD COMPRESSORS. This drawing may not, in whole or in part, be duplicated or disclosed or used for manufacture of the part disclosed herein, without prior written permission of HARTFORD COMPRESSORS.

**HARTFORD COMPRESSORS**  
Pioneers in Screw Compressor Technology  
179 SOUTH STREET  
WEST HARTFORD, CT 06110 U.S.A.

PART NAME: MSC 110MM DIMENSIONAL OUTLINE

SCALE	DRAWN BY	REVIEWED	COMPRESSOR LINE
1/8	NAME KUSEK DATE NOV 18 98	NAME DATE	MSC ~110MM
DRAWING NUMBER	D5- 056178AI		SHEET 1 OF 1 REV. 2

Back to MSC Outline  
Drawings Menu

DO NOT SCALE  
WORK TO DIMENSIONS SHOWN

REV.	ECN NO.	DATE	ZONE	CHANGES
0	711-0322	12/11/98		RELEASED
1	370-0954	FEB 17 2000	2A 2A 2C	A) WAS: 14.88. B) ADDED DIM. C) RECONFIGURED UNLOADER ASSY.

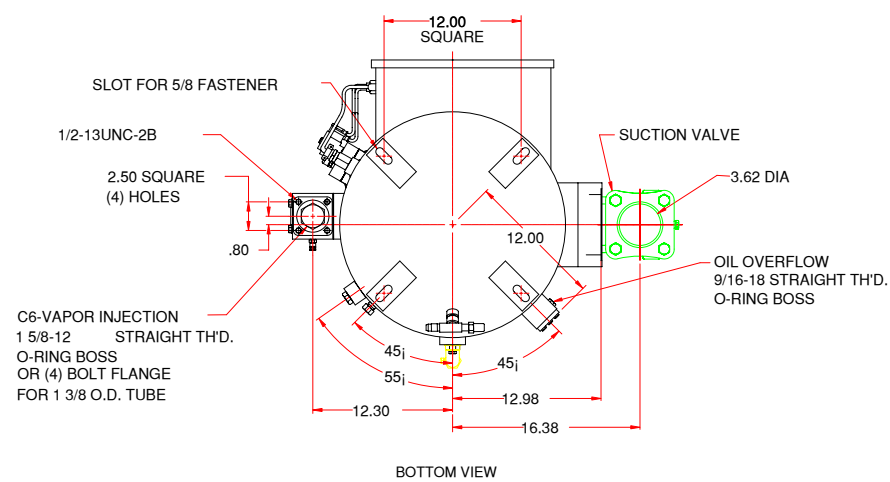
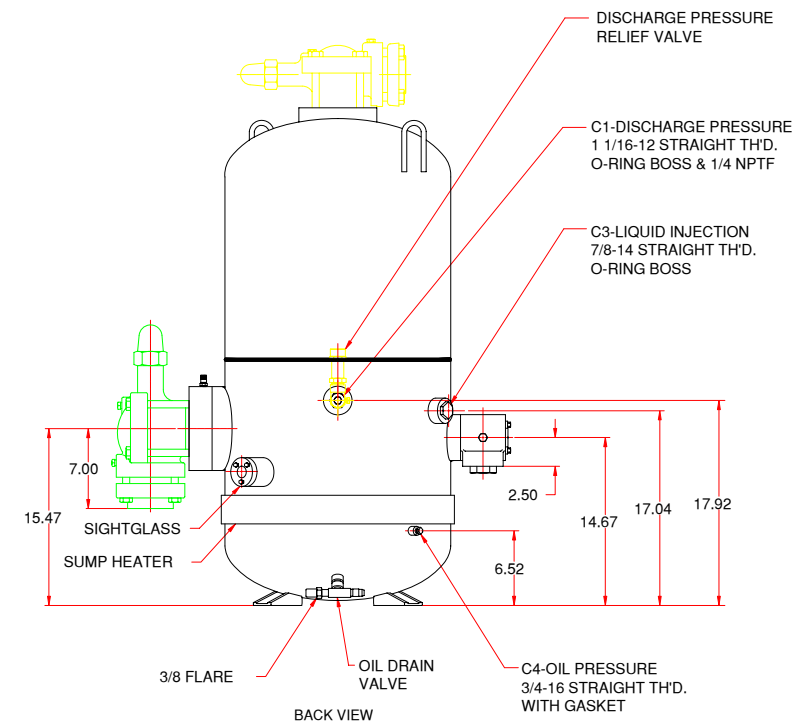
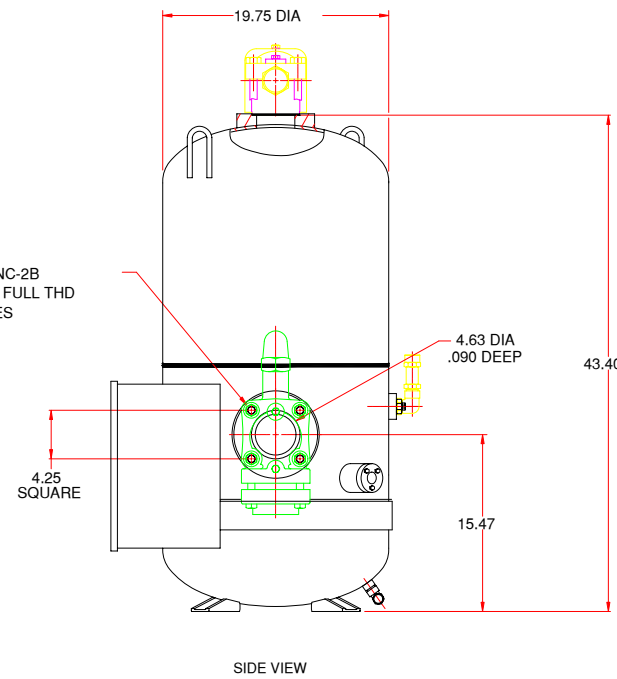
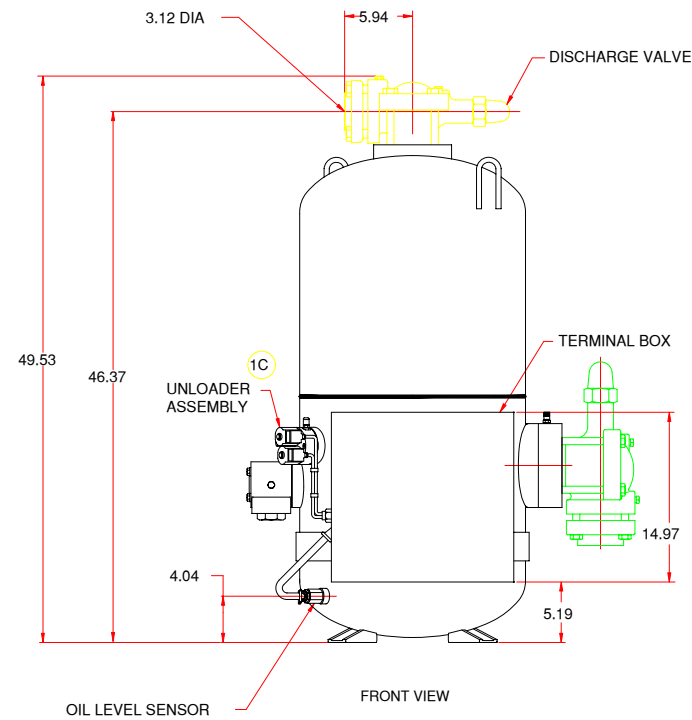
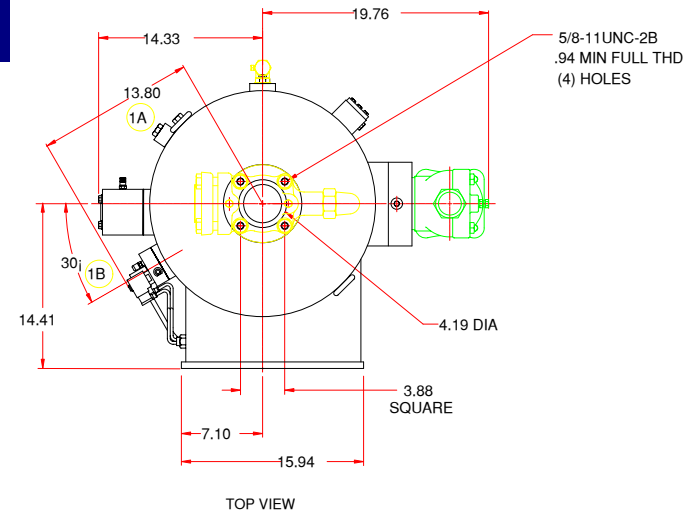

2. TO SHOW COMPRESSOR WITH DISCHARGE AND SUCTION VALVES:  
TURN OFF LAYERS "NO\_DIS\_VAL" & "NO\_SUCT\_VAL".
- TO SHOW COMPRESSOR WITHOUT DISCHARGE AND SUCTION VALVES:  
TURN OFF LAYERS "DIS\_VAL" & "SUCT\_VAL".
1. STANDARD COMPRESSOR IS SOLD WITHOUT SERVICE VALVES.
- NOTES:

This drawing contains designs and other information which are the property of HARTFORD COMPRESSORS. This drawing may not, in whole or in part, be duplicated or disclosed or used for manufacture of the part disclosed herein, without prior written permission of HARTFORD COMPRESSORS.

**HARTFORD COMPRESSORS**  
Pioneers in Screw Compressor Technology  
179 SOUTH STREET  
WEST HARTFORD, CT 06110 U.S.A.

PART NAME: 1210K & 1212K DIMENSIONAL OUTLINE

MATL:

SCALE	DRAWN BY	REVIEWED	COMPRESSOR LINE
1/8	NAME KUSEK DATE NOV 13 98	NAME DATE	MSC ~127MM

DRAWING NUMBER: **D5-056178B1** SHEET 1 OF 1 REV. 1

Back to MSC Outline  
Drawings Menu

DO NOT SCALE  
WORK TO DIMENSIONS SHOWN

REV.	ECN NO.	DATE	ZONE	CHANGES
0	711-0322	12/11/98		RELEASED
1	370-0654	FEB 17 2000	2A 2A 4B 2C 1E	A) WAS: 15.88. B) ADDED: DIM. C) ADDED: DIM. D) RECONFIGURED UNLOADER ASSY AND ADDED CALLOUT. E) WAS: 1 5/8-12 STRAIGHT THD AND 1 3/8 O.D. TUBE.

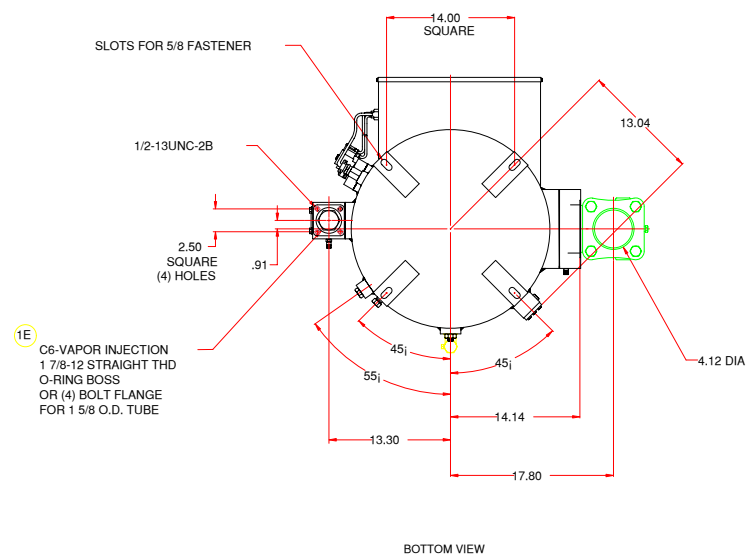
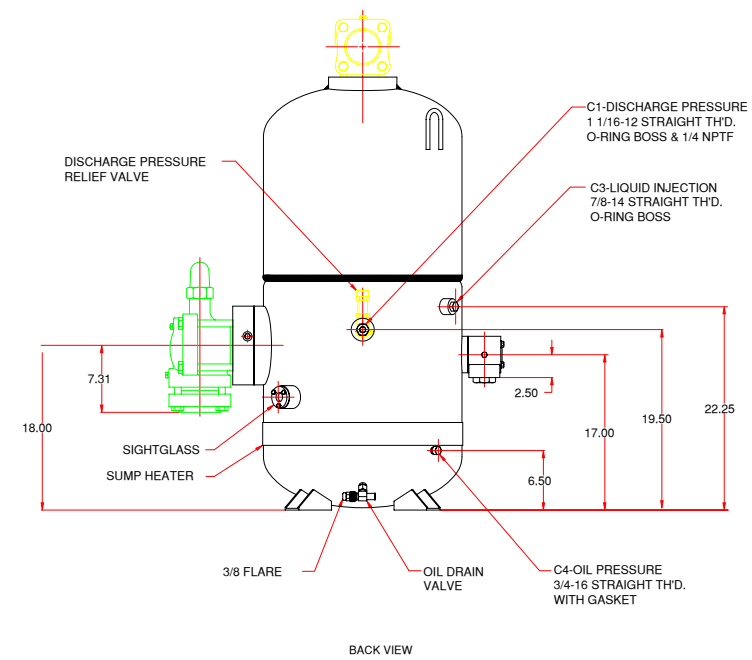
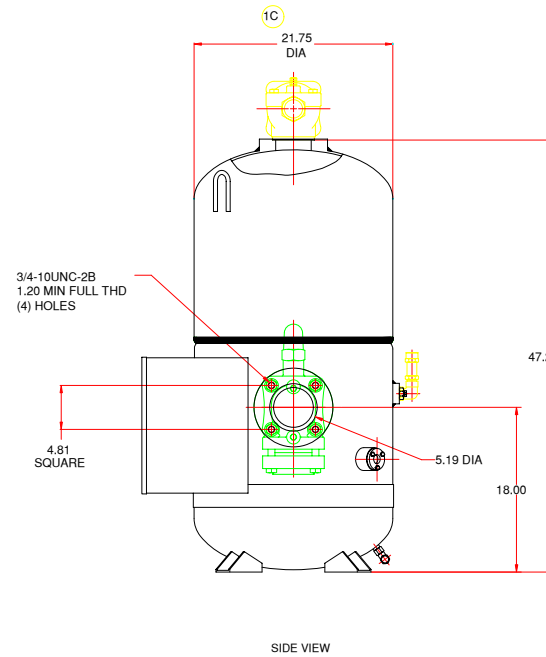
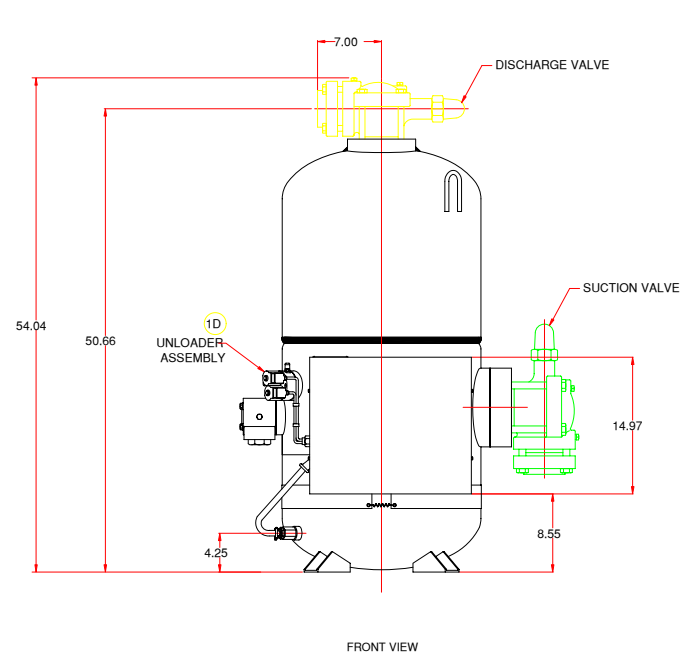
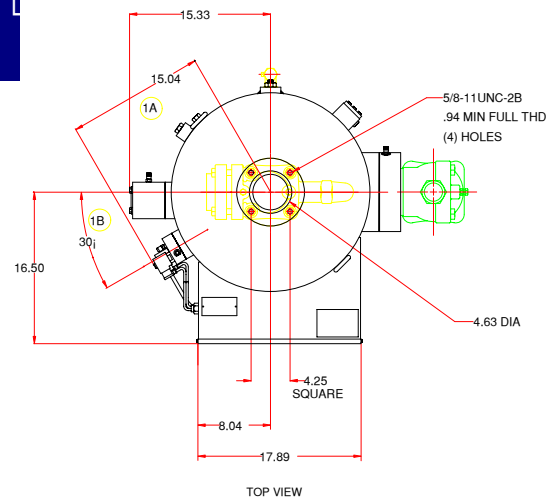

2. TO SHOW COMPRESSOR WITH DISCHARGE AND SUCTION VALVES:  
TURN OFF LAYERS "NO\_DIS\_VAL" & "NO\_SUCT\_VAL".
- TO SHOW COMPRESSOR WITHOUT DISCHARGE AND SUCTION VALVES:  
TURN OFF LAYERS "DIS\_VAL" & "SUCT\_VAL".
1. STANDARD COMPRESSOR IS SOLD WITHOUT SERVICE VALVES.
- NOTES:

This drawing contains designs and other information which are the property of HARTFORD COMPRESSORS. This drawing may not be copied or in part be duplicated or disclosed or used for manufacture of the part disclosed herein, without prior written permission of HARTFORD COMPRESSORS.

**HARTFORD COMPRESSORS**  
Pioneers in Screw Compressor Technology  
179 SOUTH STREET  
WEST HARTFORD, CT 06110 U.S.A.

PART NAME: 1215K & 1218K DIMENSIONAL OUTLINE

SCALE	DRAWN BY	REVIEWED	COMPRESSOR LINE
1/10	NAME KUSEK DATE NOV 13 98	NAME DATE	MSC ~127MM
DRAWING NUMBER	D5-056178B2		SHEET 1 OF 1 REV. 1